



## **ISO 10360**

The New Acceptance and Reverification Tests  
for Coordinate Measuring Machines



We make it visible.





### **The New Acceptance and Reverification Tests for Coordinate Measuring Machines**

The international ISO 10360 series of standards titled Acceptance and Reverification Tests for Coordinate Measuring Machines (CMM) describes in detail testing methods depending on the model, sensors and capabilities of a CMM. These standards are continually revised and supplemented to keep pace with technology.

In general, every user of a CMM obtains information on the basis of this standard. This is a good approach as it enables a comparison at the same level of different CMMs.

By the way, the extensive texts and associated illustrations on ISO 10360 can be obtained from the Beuth-Verlag in Berlin. [www.beuth.de](http://www.beuth.de)

**What exactly does "accuracy of CMMs" mean?**

It refers to the differentiation between parameters of ISO 10360 [1] and the task-specific measurement uncertainty. In order to illustrate the comparison possibilities of various CMMs, the corresponding tests must detect all key error components of a CMM. Therefore, they have been defined on the basis of typical measuring tasks on CMMs, such as length and form measurements. Therefore, statements on task-specific measurement uncertainties can be given on the basis of the specifications for certain length and form measuring tasks.

However, because a CMM deals with a number of measurement tasks, these special test results are insufficient. This led to the introduction of guidelines such as the ISO/TS 15530 [2] series where the intention is to determine and assess task-specific

measurement uncertainty for the various characteristics during workpiece measurements. All the methods described therein are based largely on the determination of combined standard uncertainty described in GUM [3] (Guide to the expression of Uncertainty in Measurement). It is also the basis for determining the least measurable tolerances with a CMM due to the methods for determining test suitability described in VDI 2617-8 [4] and VDA 5 [5].

And: there is another series of standards – ISO 23165 [6] – for CMMs. It describes the determination of test uncertainty in acceptance tests in accordance with ISO 10360. New in this regard is that instructions for determining the test uncertainty caused by the test in accordance with ISO 14253 [7] will be included with each part of ISO 10360 in the future.

[No.] See references on Page 19

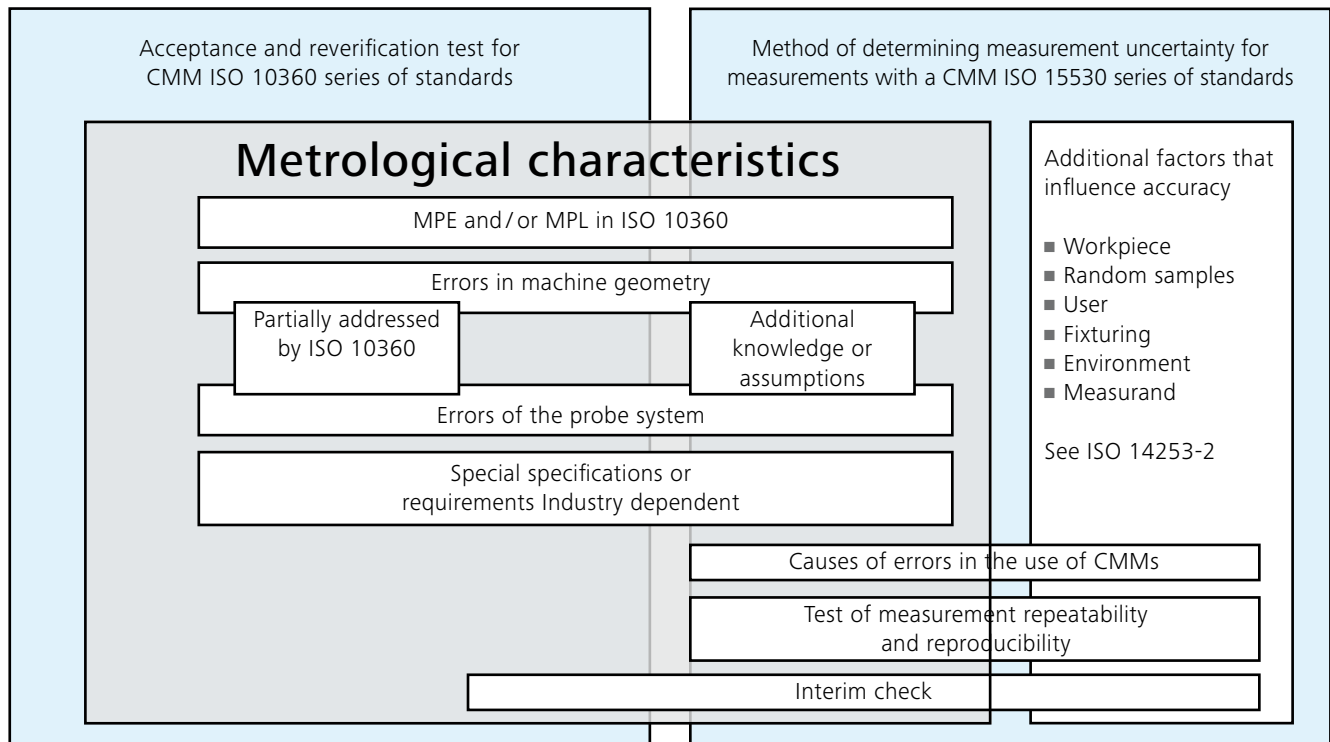

*Link between the metrological characteristics and the measurement uncertainty for the single features that appear with workpiece measurements on a CMM.*

### What is new in ISO 10360-2:2009?

In ISO 10360-2 from 2009, the following essential changes were made in comparison to the preceding version from 2001:

- New parameters for E150 and R0 were added.
- The existing designation E was changed to E0.
- The general term for E0 and E150 is now EL.
- Probing test P was removed from Part 2 and added to Part 5.
- Part 5 was revised and now contains the testing of the single stylus probing error and the multiple stylus probing error. Consequence: the test in Part 5 detects probe errors, while the tests in Part 2 primarily detect geometric errors of the CMM.
- The basis for comparable specifications was created. For large CMMs, duplex CMMs and CMMs with optical sensors. This includes, in particular, rules for the comparability of unidirectional and bidirectional probing. Consequence: the test of length measurement error can be completed not only with gage blocks, but also with ball bars, ball plates and laser interferometers.
- The rules on loading effects have been revised.
- The specifications on permissible environmental conditions are more precise.

**Simplification:** because subscripts, e.g.  $E_0$  or  $E_{0,MPE}$ , often cause graphic problems for the authors of documentation and datasheets, the terms can now be written without subscripts, i.e. E0 and MPE (E0).

**Terms:** the definitions in Part 1 of ISO 10360-1 serve as the basis for the definition of the methods in the following parts of the ISO 10360 series. They are required for precise specification and are used for uniform terminology in datasheets, user manuals and user interfaces.



*Test of length measurement error E0 with a step gauge in space.*

**Discussion:** the current definition for CMM in ISO 10360-1 only applies to machines with a movable probe system. Talks are currently being held to determine if a general term – CMS – should be introduced to expand the ISO 10360 standards to additional types of machines such as articulated arm systems, computer tomographs or laser trackers. This would ensure the comparability of the specifications of these machines with traditional CMMs.

### What is the difference between MPE and MPL?

The performance of a CMM is verified when the test results lie within specified limits. A distinction is made between two limits:

- MPE (Maximum Permissible Error) describes the measuring error when the verification requires a calibrated artifact. This is the case, for example, with length measurement error EL.
- MPL (Maximum Permissible Limit) is used if measurement errors are not determined during a test, i.e. calibrated artifacts are not required. This is the case for the repeatability range R0.

# ISO 10360-2: Using CMMs for length measurements

## What does length measurement error mean?

The length measurement error  $EL$  ( $EL$  is the general form for  $E0$  or  $E150$ ) is the error of indication of two-point distance measurements on calibrated test lengths with lateral distance  $L$  between the stylus tip and the ram axis. The standard values for  $L$  are 0 mm and 150 mm. This results in the difference between  $E0$  and  $E150$ . However, other distances are possible. If unidirectional calibrated artifacts (ball plates, ball bars, laser interferometers) are used for the test of length measurement error, or if a unidirectional measurement of step gauges is made, a short gauge block must be measured to enable comparability with the bidirectional test. This can also be accomplished through the algebraic sign-compliant incorporation of the probing errors  $PFTU$  and  $PSTU$  (see ISO 10360-5).



Compared to unidirectional measurements and sphere distance measurements, hysteresis and stylus tip radius errors are included in the results of the two-point distance measurement on the gauge block.

## How does the length measurement error $E0$ work without lateral stylus offset?

The test of length measurement error introduced with ISO 10360-2:2001 has not been changed; only the designation from  $E$  to  $E0$ . This makes it clear that lateral stylus offset is not stipulated for this test. Two-point distance measurements on calibrated test lengths must be completed to determine the length measurement error – gauge blocks and step gauges are used in standard cases. 5 different lengths in 7 locations in the measuring volume of the machine are measured. Each length is measured three times. The resulting 105 deviations from the calibrated value must not exceed the limit  $MPE(E0)$ .

## For which measurement tasks can the specification values be applied?

For the estimation of task-specific measurement uncertainties of

- Distance measurements
- Coordinate system-related location measurements
- Diameter measurements
- Radius measurements

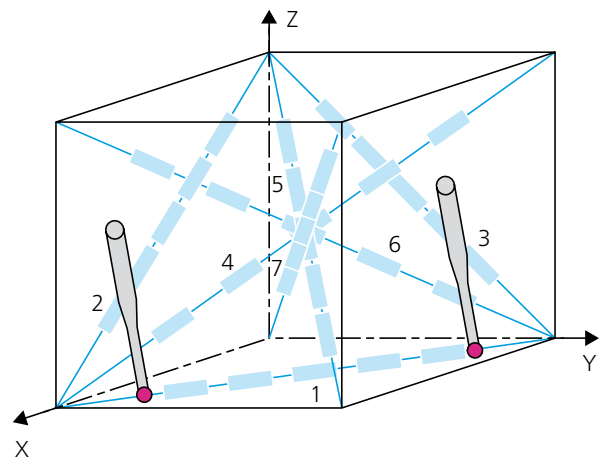

Possible orientations of the 5 gauge block lengths being measured in 7 locations.

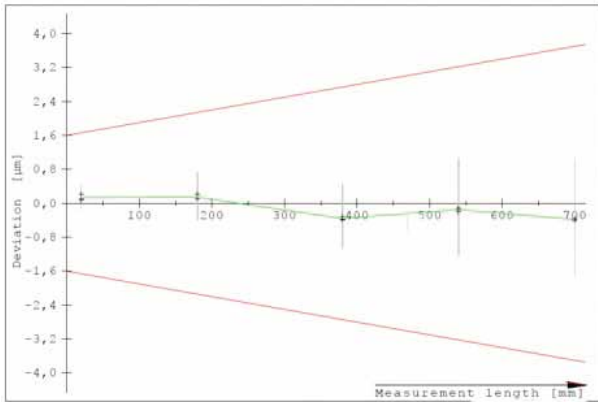

Visualization of the test results of length measurement error  $E_0$  with "specification trumpet" and the deviations of the measured gage blocks from the calibrated value.

**Specification of the maximum permissible error:** usually length-dependent as  $MPE(E_0) = A + L/K$ .  $L$  refers to the measuring length.  $MPE(E_0) = A + F \cdot L/K$  is occasionally used. This must be converted to the formula mentioned first for comparison. For example, these values are identical:  $MPE(E_0) = 2.5 + 1.5 \cdot L/333$  and  $MPE(E_0) = 2.5 + L/220$ .

### Which factors lead to test uncertainty of length measurement error?

The most important factors from the calibration uncertainty of the artifact used and from environmental influences such as temperature and cleanliness. The uncertainty of the expansion coefficient of the artifact also plays a role. Additional factors include the orientation and fixturing of the artifact. Users should ensure adherence to the permissible operating and environmental conditions.

### How is the repeatability range $R_0$ of length measurement error calculated?

The range is calculated from the highest minus the lowest value of length measurement error  $E_0$  from each of the three repeat measurements of the five lengths in the seven locations. In other words, 35 ranges are determined from the data captured without lateral stylus offset without additional measuring work, and compared to repeatability range  $MPL(R_0)$ .

### How is the $E_{150}$ length measurement error determined with lateral stylus offset of 150 mm?

The errors of five calibrated test lengths are measured in two 2D diagonals at a standard distance  $L = 150$  mm from the center of the stylus tip to the ram axis. If the lateral offset of 150 mm is not possible with one sensor, the length of the offset must be entered in the specifications, e.g.  $E_{40}$ . Instead of a measurement in two diagonals, a measurement in only one diagonal is possible, but with two opposing styli. Unlike the stylus arrangement in the direction of the ram, the results for a test with an offset stylus include rotational errors of the CMM, in particular.

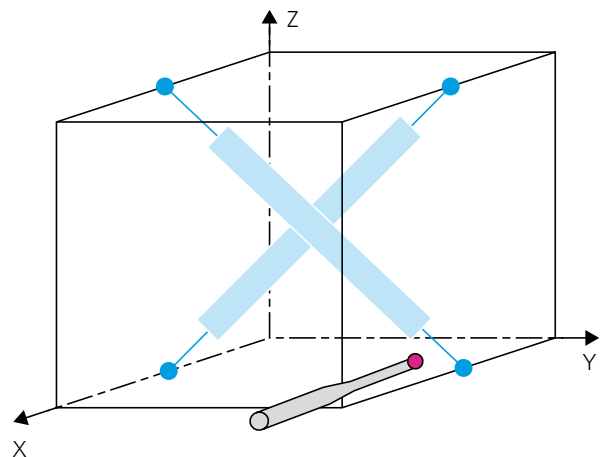

A possible variation of the  $E_{150}$  test are two 2D diagonals measured with a single stylus laterally offset by 150 mm.

# ISO 10360-3: CMM with a rotary table as fourth axis

## What does the specification of the parameters

### FR, FT and FA mean?

**The procedure:** two test spheres with a diameter between 10 mm and 30 mm are arranged diametrically on the rotary table. The radial distance to the rotary axis is 200 mm each. The two spheres are also 200 mm apart in the axial direction. Lower sphere A will be located near the rotary table surface. For large rotary tables, the manufacturer can also specify the four-axis errors for distances of 400 mm or 800 mm. Six probing points are recommended for the measurement of test spheres: four on the equator and two near the poles in the direction of the stylus.

**Preparation:** before measuring the test spheres, the rotary table axis is determined using the method described in the user manual. The workpiece coordinate system is determined with its origin in the center of test sphere B, the primary axis parallel to the rotary table axis and the direction of the secondary axis is defined through the center of test sphere A.

**The measurement:** both test spheres are measured alternately in 29 rotary table positions: beginning from the 0 degrees position in seven positions up to 810 degrees forwards and then in 14 positions backwards to -810 degrees. Then forwards again to the starting position of 0 degrees.

**Too big?** ISO 10360-3 specifies other angular positions for CMMs whose measuring range does not completely cover the rotary table. Both spheres are measured in the 0 degrees position, which is approached in the 0, 14 and 28 positions. Otherwise, only test sphere A located near the rotary table surface is measured in positions 1–13. Test sphere B, which is raised 200 mm, is used for positions 15–27. Both test spheres are therefore measured 16 times each.

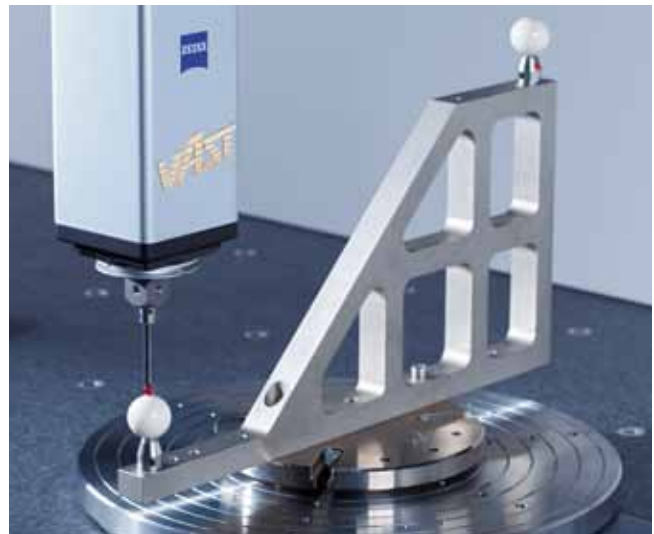
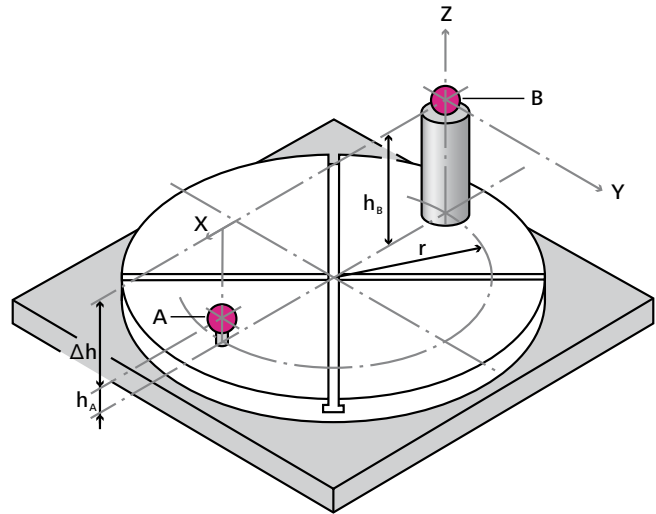

*The rotary table check artifact with arrangement of the two test spheres as per ISO 10360-3. Used for the standard-compliant completion of acceptance tests and regular monitoring.*



## What is...

### ... FR radial four-axis error?

This is the range of the center locations of test spheres A and B from all rotary table positions in the radial direction in the workpiece coordinate system.

### ... FT tangential four-axis error?

This is the range of the center locations of test spheres A and B from all rotary table positions in the tangential direction in the workpiece coordinate system.

### ... FA axial four-axis error?

This is the range of the center locations of test spheres A and B from all rotary table positions in the axial direction in the workpiece coordinate system.

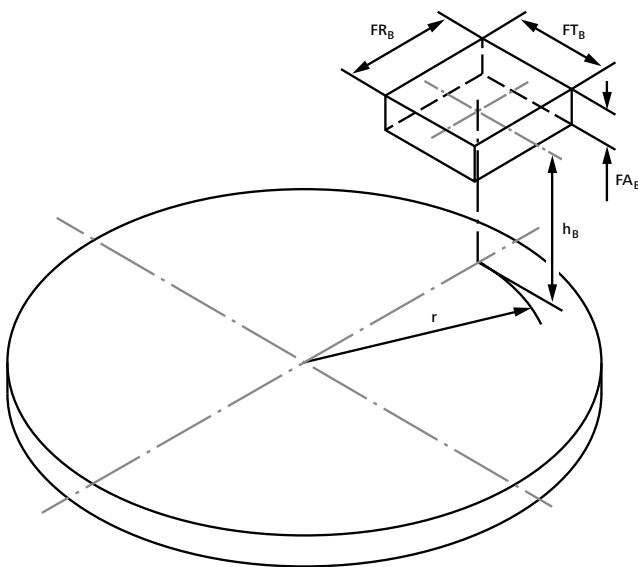

Schematic display of the four-axis errors FR, FT and FA for test sphere B.

## Which test uncertainty factors play a role?

You must ensure that the test spheres are mounted so that they are stable and rigid. The form of the spheres is included in the test results. Therefore, the sphere form should be negligibly small in relation to the specific limits of the four-axis error. Or, they must be included in the calculation of testing uncertainty. Because the diameter of the test spheres is not included in the test results, they do not have to be calibrated. The calibration of the rotary table axis requires the utmost care. Corresponding instructions can be found in the user manual – also in reference to the operating temperature of the rotary table.

**Thermal influences:** require special attention because they influence the test results. Drafts, air flow from an air conditioner, non-tempered stylus systems and the calibration of the rotary table, for example, have a negative impact before the CMM or rotary table reaches operating temperature.

## For which measurement tasks can the specification values be applied?

For the estimation of task-specific measurement uncertainties of

- Distance measurements with a rotary table
- Position tests of boreholes in different rotary table positions
- Diameter measurements with a rotary table
- Radius measurements with a rotary table
- Form inspections with a rotary table

# ISO 10360-4: CMM in scanning mode

## What does the specification of parameters THP and $\tau$ mean?

**The procedure:** four defined paths on a test sphere with a diameter of 25 mm are scanned with a stylus. The stylus tip has a diameter of 3 mm. It is recommended to have the stylus slanted so that all machine axes can be included in the scanning process. The location of the four scanning paths: they are specified on the equator of the test sphere, offset by 8 mm in a parallel plane, a 180 degree segment over the pole and another 180 degree segment rotated 90 degrees and offset 8 mm from the pole. The equator and pole are defined by the orientation of the stylus.

**The symbols:** for scanning probing error THP, P (predefined) stands for scanning known contours, H refers to the high point density with point spacing of 0.1 mm. Additional parameters for low point density L (low) with point spacing of 1 mm or N (non-predefined) are not widely used.



*The diameters of the test spheres and the stylus tips are specified in ISO 10360-4 to enable comparisons of runtimes.*

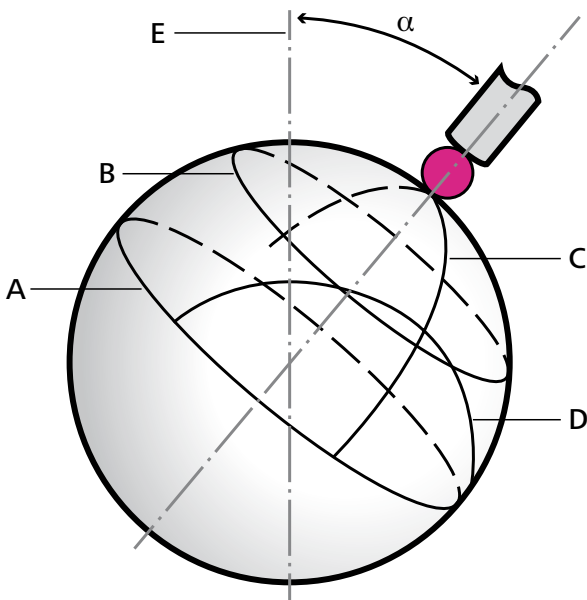

*Visualization of the four scanning paths specified in ISO 10360-4.*

**The time:** because there is a connection between scanning accuracy and speed, the scanning test is a performance test in which time  $\tau$  must be specified for the runtime of the four segments.

**What is THP scanning probing error?**

This is the range of the calculated radial distances  $R_{max} - R_{min}$  of the points of all four sections scanned in the Known Contour mode. Furthermore, the maximum absolute error of all single radial distances from the calibrated radius of the test sphere must not be larger than the specification value for THP.

**Scanning test duration:**  $\tau$  is the runtime of the four scanning paths from a starting position 10 mm from the test sphere to a final position 10 mm from the test sphere.

**How does the test sphere have to be set up?**

It must be stable and rigid and you must ensure that the stylus system is securely screwed together. The form of the test sphere and the stylus tip diameter influence the test results. Therefore, the sphere form should be negligibly small in relation to the specified maximum permissible error of the scanning probing error or it must be included in the calculation of test uncertainty. Furthermore, the diameter of the test sphere must be calibrated due to the calculation of the absolute radial error to the calibrated radius. Finally, the test sphere and stylus tip must be clean and must not be damaged.

**Where can the specification values of the scanning probing error be applied?**

When estimating task-specific measurement uncertainties of size, form and location measurement with scanning. The scanning probing error represents the performance of the total system and does not distinguish between dynamic and static influences.

# ISO 10360-5: Multi and single stylus probing error of CMMs with contact probe systems.

## What does the specification of parameters PFTj, PSTj, PLTj, PFTU and PSTU mean?

The procedure for **single stylus probing error**: a test sphere with a diameter between 10 and 50 mm is probed in 25 single points by a stylus. They are spread evenly over a half-sphere. Part 5 recommends stylus lengths of 20, 30, 50 or 100 mm.

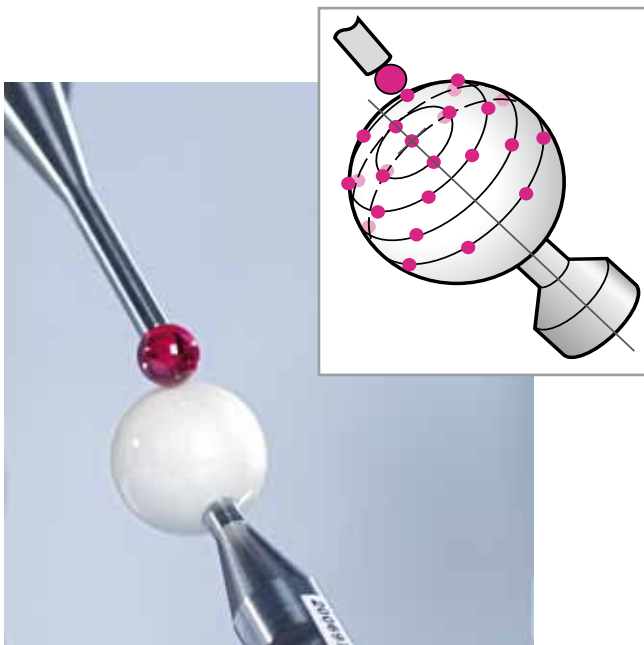

*Distribution of the 25 probing points in accordance with ISO 10360-5.*

The procedure for **multi-stylus probing error**: measurements with 5 styli on a test sphere with a diameter between 10 and 50 mm. These 5 styli are oriented parallel to the machine axes. On a fixed stylus system, the 5 star-shaped styli have the same nominal diameter. On an articulating system, a single stylus is moved in the 5 orientations. A point pattern comprised of 25 single points is recorded with each of the 5 styli or stylus orientations. This point pattern is evenly spread over a half sphere. This results in a total of  $5 \times 25 = 125$  probing points. Part 5 recommends 10, 20, 30, 50, 100, 200 and 400 mm stylus lengths for fixed multi-stylus-systems and 50, 100, 200 and 400 mm probe-tip-offset length for articulating systems.

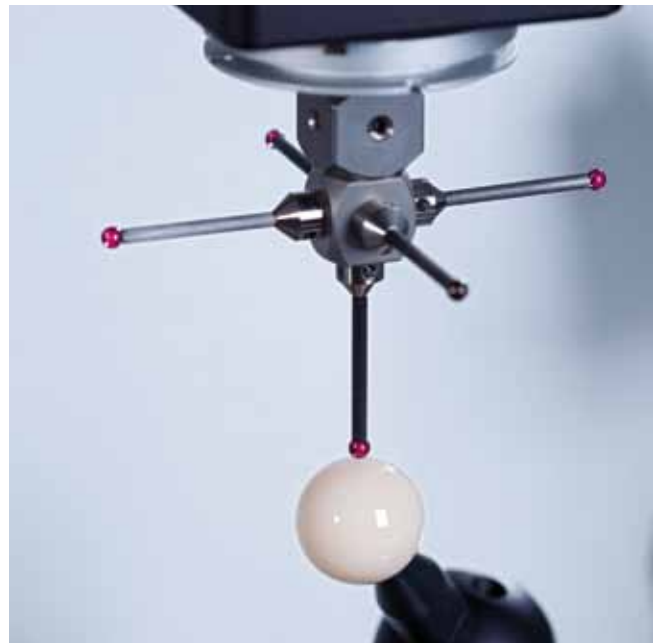

**Tip:** If a rack for automatic change of stylus systems is available, the stylus system should be changed before each sphere measurement.

**From what is the PFTU single stylus form error calculated?**

From the range of 25 radial distances. These are based on the center point of the Gaussian least-squares sphere fit. This test is generally completed before all other tests because possible weaknesses in the probe system can be quickly detected through the test.

**From what is the PSTU single stylus size error calculated?**

From the difference of the calibrated diameter of the test sphere to the diameter of the Gaussian least-squares sphere fit calculated from the 25 probing points. For PSTU, a maximum permissible limit error is not specified, but the result is used to achieve comparable results for unidirectional measurements with bidirectional measurements according to ISO 10360-2. The symbol S refers to size. U stands for single stylus and comes from the word unique.

**How does the test sphere have to be set up?**

It must be stable and rigid and the stylus system securely screwed together. The form error of the test sphere and of the stylus tip influence the test results. Therefore, the sphere form should be negligibly small in relation to the specified maximum permissible error of the probing error. Otherwise, they must be included in the calculation of test uncertainty. The diameter of the test sphere must be calibrated due to the calculation of PSTU. Test spheres and stylus tips must be clean and undamaged. Caution: the position of the test sphere affects the test results, particularly the distance between the reference sphere and test sphere. If a long distance is selected, the geometry errors of the CMM, in addition to probe-specific influences, greatly affect the test results.

# ISO 10360-5

## **What is new in ISO 10360-5:2010?**

**The symbols:** a distinction is now made between articulating systems with and without CAA correction, i.e. between a single qualification of each stylus orientation and the more convenient derivation of the qualification data of any position from a few qualified positions. For a better overview of the parameters defined in Part 5, their designation was expanded to 4 letters, e.g. PFTU.

**The first letter:** indicates that it deals with the error of indication for the probing error P (probing) of the CMM.

**The second letter:** a distinction is made here between errors of indication for form (F), size (S) and location (L).

**The third letter:** describes a tactile probe with the letter T.

**The fourth letter:** describes the type of system.

E (empirical) stands for an articulating system with individual qualification of every single position.

I (inferred) for articulating systems with qualification of any position from a few individual qualification positions.

M (multi) stands for fixed multi-stylus.

N (numerous) stands for multi-probes

U (unique) stands for a single stylus.

**Specification:** The example described above, PFTU for the single stylus form error corresponds to the previous short, but less clear designation P.

## **What is the PFTj multi-stylus form error?**

The form of the Gaussian least-squares sphere fit calculated from all 125 single points. j is the placeholder for system type E, I, M and N. See the description of the fourth letter above.

## **What is the PLTj multi-stylus location value?**

The maximum range of the centers of the 5 single spheres in the X, Y and Z direction. j is also the placeholder here for the system type.

## **What is the PSTj multi-stylus size error?**

The difference of the total sphere diameters of the Gaussian least-squares sphere fit calculated from all 125 probing points compared to the calibrated diameter of the test sphere.

(j is the placeholder for the system types E, I, M and N as described for the fourth letter above).

## **Where can the specification values of the single and multiple stylus probing errors be applied?**

For the estimation of task-specific measurement uncertainties: the single stylus form error for inspections of form characteristics with single points; the multi-stylus probing errors for inspection of characteristics of size and length if several styli or different orientations of articulating styli are used.

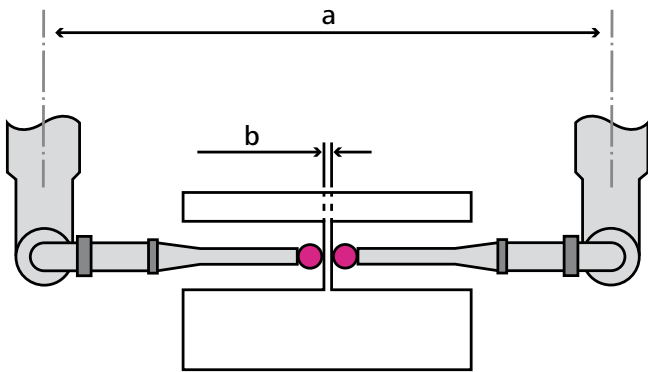

With just one stylus rotated 90 degrees, the distance dimension  $b$  in this example could be determined with low task-specific measurement uncertainty. This requires being able to probe with a rotated stylus.

The multiple stylus probing system error is usually not specified for CMMs that primarily use stylus systems with short lateral styli, or absolutely no lateral offset.

This can apply, e.g. to multisensor CMMs if the majority of applications is limited to measurements in the table plane.

#### ISO 10360-6 software test for Gaussian algorithms:

this is a software test to check the errors in the calculation of standard geometric elements in measuring software. The Gaussian best fit method (see box) is checked. For this, the test data is imported and evaluated. The difference in the results of the calculated geometric elements and the reference data are evaluated. Test data varies. Parameters such as location, orientation, size and angle of the elements are overlaid with defined form errors and cover both full elements and segments. By the way: the test as per ISO 10360-6 is not performed by the user, but by the manufacturer who can issue a certificate about the magnitude of the result differences.

**Johann Carl Friedrich Gauss:** German mathematician, astronomer and physicist (1777 – 1855) from Göttingen had a wide range of interests. Within one year of his death, the King of Hanover printed memorial coins inscribed with *Mathematicorum Principi* (the prince of mathematicians) and the likeness of Gauss.

# Handling test uncertainty and task-specific measurement uncertainty

## What information does test uncertainty

### ISO/TS 23165 deliver?

ISO/TS 23165 describes which uncertainties are already included within the limits of the specified maximum permissible errors MPE. Furthermore, it describes the uncertainties corresponding to ISO 14235-1 that must be accounted for by the person conducting the test. Determining combined standard uncertainty is seen as a general approach.

$$u_c(y) = \sqrt{c_1^2 u^2(x_1) + c_2^2 u^2(x_2) + \dots + c_n^2 u^2(x_n)}$$

These are the four key factors that lead to test uncertainty of the length measurement error in accordance with ISO 10360-2:

- Calibration uncertainty of the artifact used
- Unawareness of the exact thermal expansion coefficient of the artifact
- Uncertainty of temperature capture
- Uncertainties caused by the fixturing and orientation of the artifact

These are the three factors that lead to test uncertainty during the probing test:

- Form error of the test sphere
- Calibration uncertainty for the determination of the form error of the test sphere
- Uncertainty caused by fixturing

The ISO/TS 23165:2006 technical specification on determining test uncertainty is based on the procedure described in ISO 10360-2:2001.

For ISO 10360-2:2009 and ISO 10360-5:2012 which were published after ISO/TS 23165:2006, the determination of test uncertainty will appear in the future as an ISO standard with a new structure:

- ISO 23165-1 General and Terms
- ISO 23165-2 test uncertainty during testing in accordance with ISO 10360-2:2009
- ISO 23165-5 test uncertainty during testing in accordance with ISO 10360-5:2010

For each part of the ISO 10360 series, long-term plans call for the allocation of a corresponding part of the ISO 23165 series to determine test uncertainty.

**Responsibility:** in accordance with the decision rules as per ISO 14253-1, test uncertainty is always the responsibility of the person conducting the test. This means: during acceptance testing, the manufacturer must verify that the specifications have been met – minus the test uncertainty. During the reverification test, the user must show that the specifications have not been met – plus test uncertainty.

**Specification trumpet:** in accordance with ISO 23165, there are two possible ways to show the test results of length measurement error as per ISO 10360-2 and the corresponding test uncertainties. The single error values, including uncertainty range, are shown on the left. Alternately, the measurement uncertainty range is entered at the specification limit on the right.

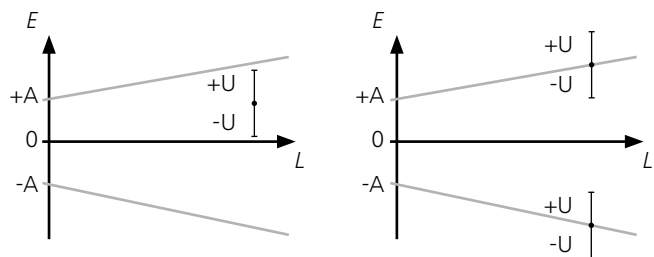

**A** Positive constants given in micrometers ( $\mu\text{m}$ ); provided by manufacturer

**L** Measured length in millimeters

**E** Length measurement error in micrometers

**U** Test uncertainty

**Note:** the specifications apply for any location and/or orientation of the length measurement artifact within the measuring volume of the CMM.



### What information does the task-specific measurement uncertainty ISO/TS 15530 deliver?

ISO/TS 15530-1 provides an overview of uncertainties of task-specific measurement uncertainties for three main categories:

- Machine factors
- Measurement plan factors
- External factors

Examples of machine factors are:

- Geometry errors of the CMM
- Dynamic machine influences
- Errors of the probe system
- Environmental conditions (temperature, vibration)

Measurement plan factors include the user-selected position and orientation of the workpiece in the measuring volume of the CMM, as well as the specified stylus systems, the probing strategy and the selected calculation methods.

External factors include workpiece influences (deformation through fixturing, temperature), contamination, surface quality and form errors.

Two procedures are currently described in the ISO 15530 series to calculate the task-specific measurement uncertainty:

- Determination of measurement uncertainty by means of calibrated workpieces in accordance with ISO 15530-3 is generally applied for "simple" workpieces that have few features or for workpieces in serial measuring operations for which the time needed for the one-time determination of measurement uncertainty is worth the effort. The uncertainty influences that have an impact are captured through repeat measurements of a calibrated workpiece. Note: additional influences that do not occur during repeat measurements must also be accounted for mathematically.
- The VCMM simulation procedure in accordance with ISO 15530-4 is suitable for the flexible use of CMMs with constantly changing workpieces. In accordance with GUM, this method generates a computer-aided mathematical model of the inspection process in which a maximum number of relevant influences are reproduced. In repeat simulated runs, these influences vary within their estimated

possible value range. The uncertainty, which is then shown in the measuring record, is determined from the variation of the measuring results.

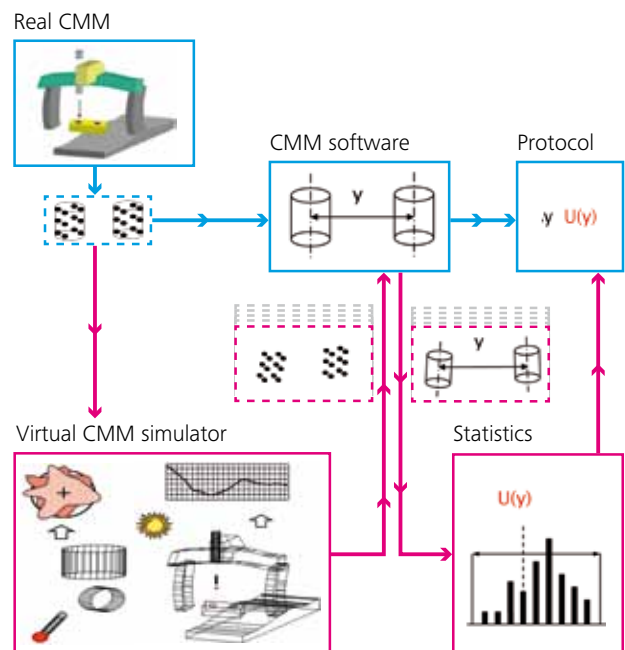

**Advantage of the simulation procedure:** measurement uncertainties are determined largely automatically and require minimal operator expertise. This expertise has already been implemented in the simulation software as per GUM and experts are responsible for configuration and verification on the affected measuring machine. The VCMM is therefore particularly well suited for measurement in which data is captured via single points at defined measuring locations. This occurs, for example, when calibrating artifacts or workpieces.

**By the way:** a second level of the VCMM has been in the works for some time now. It is being expanded to account in particular for the influences of the element form and the scanning procedure for the capture of large point quantities. In the function-oriented measurement of workpieces, large point quantities are used to obtain more information about the workpiece surface and thus to reduce the task-specific measurement uncertainty.

**Measurement uncertainty reduced through many measured points**

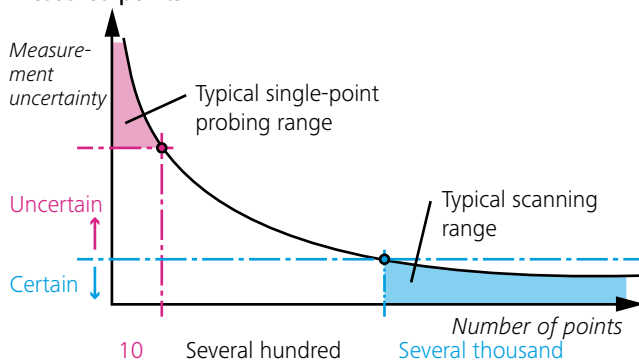

**Two outstanding standards:** until now there has been no international standard for the methods for determining test suitability of measurements on a CMM as described in VDI 2617-8 or the evaluation of uncertainty through measurement uncertainty budgets described in VDI/VDE 2617-11 of the same series of VDI guidelines. Test suitability as per VDI/VDE 2617-8 sets the task-specific measurement uncertainty in relation to the available feature tolerance.

$$g_{pp} = 2 \cdot \frac{U}{T} \leq G_{pp} \quad \text{for two-sided tolerance } T$$

$$g_{pp} = \frac{U}{T} \leq G_{pp} \quad \text{for one-sided tolerance } T$$

**What is the reason for this comparison of required tolerances to the actual measurement uncertainty?**

It allows you to determine if a measuring device or a measuring process can be used for a specific task. It also enables determination of the lowest measurable tolerance for the testing equipment. This principle also provides the foundation for VDA 5, a practical method based on the rules of GUM.

VDI/VDE 2617-11 is a measurement uncertainty budget table that provides support and instructions for the user through templates on a computer for a certain range of features. This procedure takes into account key influencing parameters like the number and distribution of probing points, geometry errors of the CMM, stylus influences and temperature. The individual contributions for the uncertainty budget are determined through partially simplified assumptions. Residual geometry errors of the CMM are derived, for example, for the machine specifications. Therefore, this procedure generally produces uncertainty values that are more on the safe side, i.e. tend to be too large.

**How are test suitability and the lowest measurable tolerance determined?**

On the basis of test suitability determined in accordance with VDI/VDE 2617-8 or VDA 5, the lowest measurable tolerances can be ascertained under the assumption of a certain suitability value. Test suitability  $g_{pp}$  is assessed through a comparison of the extended measurement uncertainty  $U$  to the required tolerance  $T$  in accordance with ISO 14253 and VDI/VDE 2617-8 and VDA 5. The test suitability is calculated from  $g_{pp} = 2 \times U/T$  for two-sided tolerances and  $g_{pp} = U/T$  for one-sided tolerances. Test suitability  $g_{pp}$  shall not exceed the limit  $G_{pp}$  which usually lies between 0.2 and 0.4. A lower limit thus means more measuring investments where the majority of the drawing tolerance remains in production as a production dispersion range in this case.

### **How is the lowest measurable tolerance determined with a specific measuring device?**

Practical experience shows that the experimental approach as described in VDI 2617-8 and in VDA 5 is effective. This is also because the extended measurement uncertainty  $U$  was ascertained through repeat measurements under real environmental conditions on the machine being evaluated. For these repeat measurements, the CMM Check, which is commercially available, can be used for example. With gauge blocks, ring gauges and plug gauges, this check features calibration values and recreates frequently recurring measuring tasks on the CMM.

### **Which stylus system should be used to determine the lowest measurable tolerance?**

The system that will be used later for workpiece measurements. The location and clamping position in the measuring volume should be selected to correspond with subsequent workpiece measurements. Parameters that influence the measurement uncertainty of this experimental approach include the calibration uncertainty of the artifact, systematic and random influences during the minimum 20x repeat measurements – derived from the procedure, the application, from the workpiece and from the measuring machine including the stylus system. Furthermore, the temperature and expansion coefficient of the workpiece play a role. The lowest drawing tolerances suitable for measuring were determined with a CMM Check – e.g. for a 50 mm inner diameter and for 50 mm and 400 mm distance measurements. The GageMax used is suitable for deployment directly in production without an enclosure and specified at  $MPE(E0) = 2.2 + L/300$  in accordance with ISO 10360-2.

**Repeatability range:** it has been shown that the CMM has to exhibit extremely minor systematic and random errors so that one-fifth of the drawing tolerance is not exceeded. The repeatability range of the 50 mm gauge block measurement with GageMax had to be better than  $0.09 \mu\text{m}$  to achieve  $6 \mu\text{m}$  as the lowest measurable tolerance for a two-point distance measurement. The lowest measurable tolerances for typical features are frequently given for CMM model and size – in addition to the specifications as per ISO 10360.

### **Bibliography**

- [1] ISO 10360 Part 1–6, Geometrical product specifications (GPS) – Acceptance and reverification tests for coordinate measuring machines (CMM).
- [2] ISO/TS 15530 Part 1, 3 and 4, Geometrical product specifications (GPS) – Coordinate measuring machines (CMM): Technique for determining the uncertainty of measurement.
- [3] Guide to the expression of uncertainty in measurement (GUM), ISO/IEC Guide 98-3:2008
- [4] VDI/VDE Directive 2617 Parts 2.1–13, Accuracy of coordinate measuring machines – Parameters and their reverification.
- [5] VDA 5 Test suitability, Verband der deutschen Automobilindustrie e. V. (VDA), Frankfurt/M. 2nd Edition 2010
- [6] ISO/TS 23165, Geometrical product specifications (GPS) – Guidelines for the evaluation of coordinate measuring machine (CMM) test uncertainty, 2006.
- [7] ISO 14253-1, Geometrical product specifications (GPS) – Inspection by measurement of workpieces and measuring equipment – Part 1: Decision rules for proving conformance or non-conformance with specifications, 1999.

**Carl Zeiss**  
**Industrielle Messtechnik GmbH**  
73446 Oberkochen/Germany  
Sales: +49 7364 20-6336  
Service: +49 7364 20-6337  
Fax: +49 7364 20-3870  
Email: [imt@zeiss.de](mailto:imt@zeiss.de)  
Internet: [www.zeiss.de/imt](http://www.zeiss.de/imt)

**Carl Zeiss**  
**Industrial Metrology, LLC**  
6250 Sycamore Lane North  
Maple Grove, MN 55369/USA  
Phone: +1 763 744-2400  
Fax: +1 763 533-0219  
Email: [metrology@zeiss.com](mailto:metrology@zeiss.com)  
Internet: [www.zeiss.com/metrology](http://www.zeiss.com/metrology)